

# SHW OFFROAD

## 5th Gen 4Runner Drawer System Install

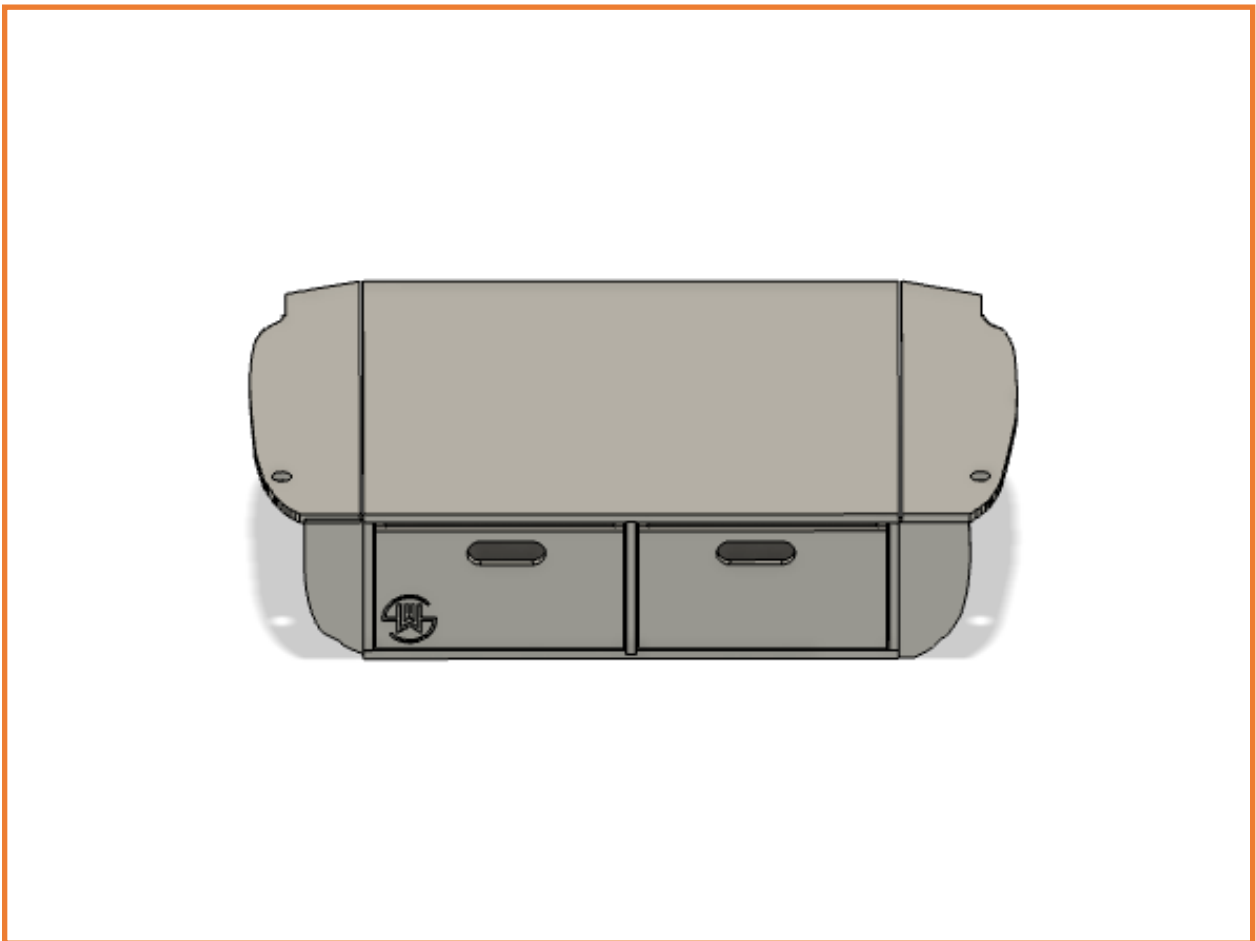

1. Begin by removing the factory sliding tray from the vehicle if equipped. Once removed we suggest adding some dampening material on the cargo floor. Dynamat is a good solution.
2. Once that is completed, remove the tie down cover and bump from behind the rear seat. Do this by pulling up on the plastic tab to expose the bolt that anchors the tie down to the vehicle. Remove the bolt with a 10mm Socket.



3. Remove the trim piece behind the rear seats. Install the included L brackets using the factory tie down bolts.

4. Install the driver side wing cap. The wing cap screws will be installed from the inside of the drawer system. Install the wings if you have an Expedition Series Drawer system. The hinges are already mounted, you just need to start the hooks at the top, and push at the bottom. More info here: <https://shwoffroad.com/wp-content/uploads/2023/03/SUV-Wing-Install.pdf>

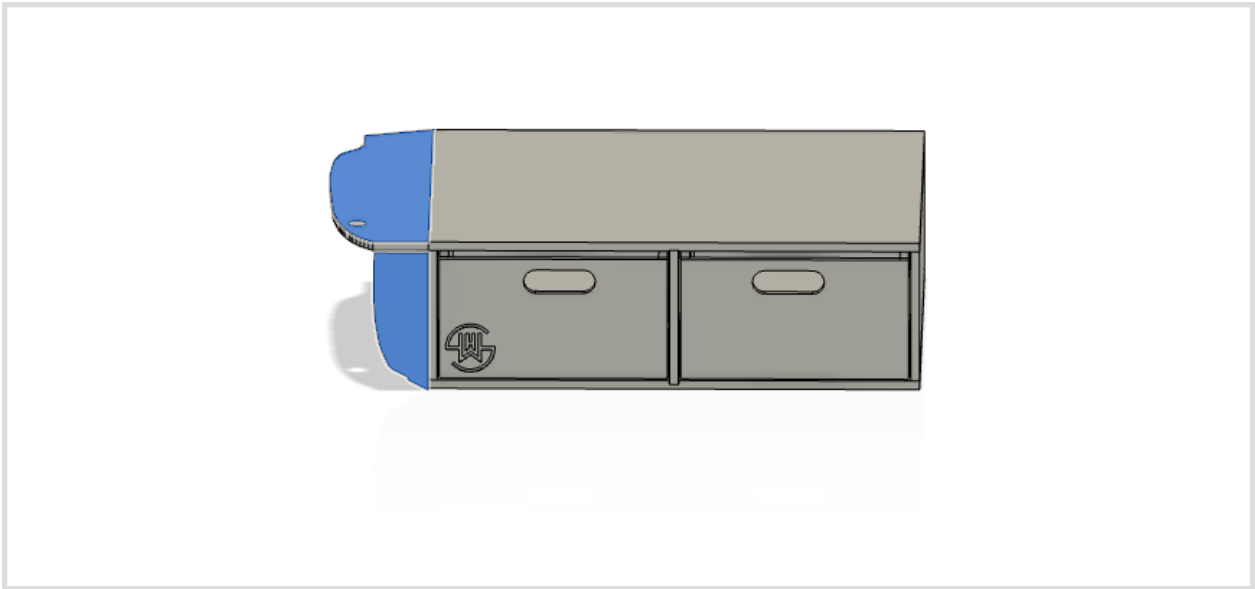

5. Slide the drawer system into the vehicle. Be careful with the wing cap on the driver side. If wings are installed make sure they are in the upright position.

6. Install the driver side wing cap. Install the wing supports if you have an Ultralite drawer system.

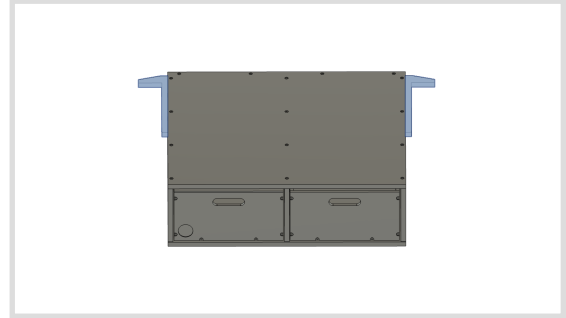
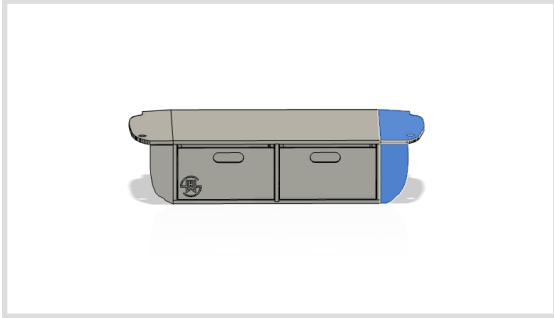

7. Line up the drawer system with the L Brackets. Thread the included machine screws (Phillips head) into the threaded inserts on the back of the drawer system. Check wing fitment, then torque them down. Finish by looping the included straps to the tailgate side factory tie downs.