

SHW OFFROAD

Jeep JLU Drawer System Install

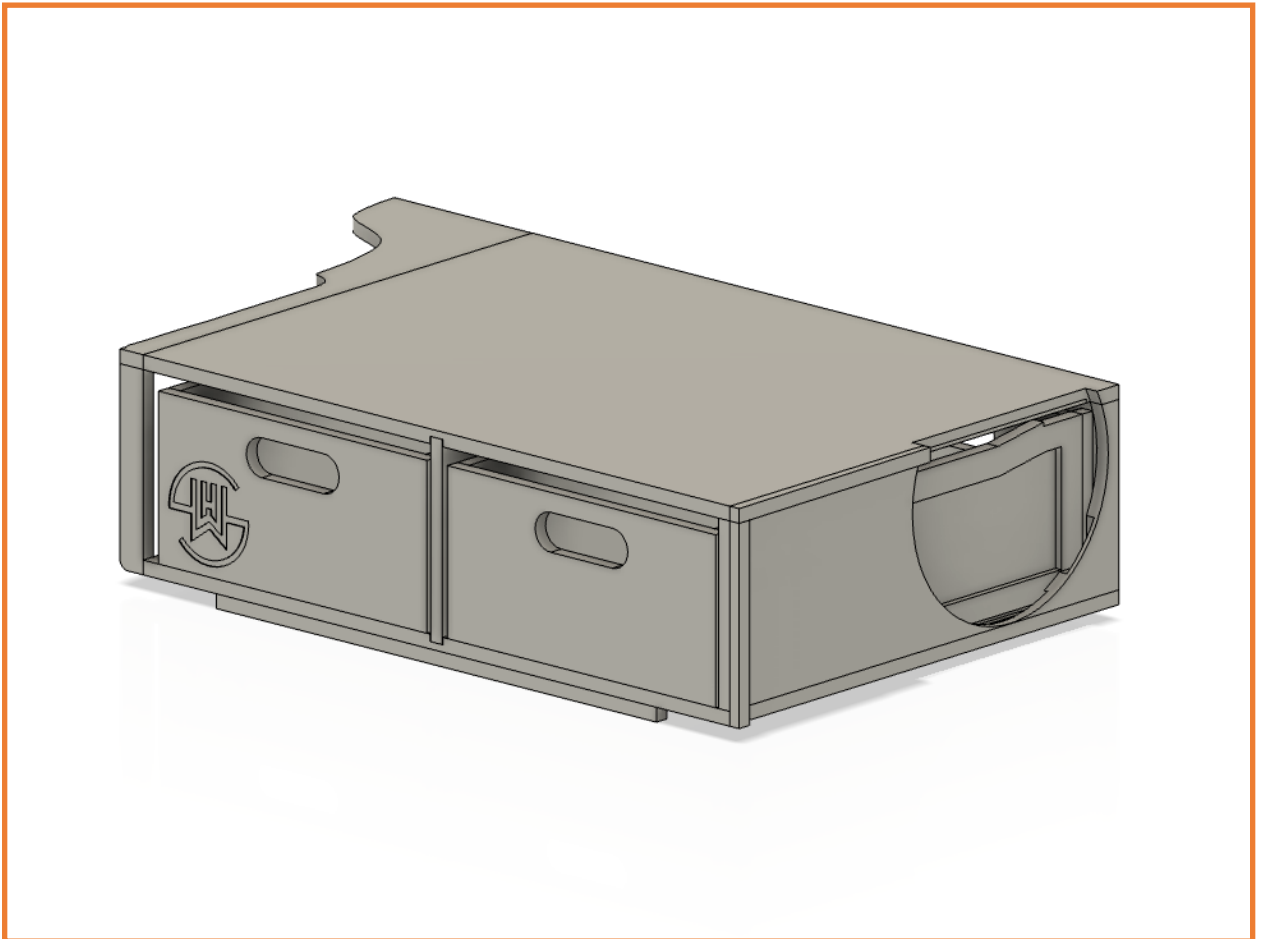

1. Begin by removing the factory tie down loops in the cargo area. There should be 6 of them. This will require a T40 Torx bit.
2. Remove the cargo floor, but be sure to retain the side trim pieces on top of the tie down points.



3. Remove the drawers from the system chassis. Also remove the driver side wing and filler plate (you can install the passenger side filler plate now). *Be careful removing the drawer from the chassis if you are installing an expedition series system. The drawer must be pulled straight out. Press the locking tab and pull straight out in the most outright position to free the drawer from the chassis. If you have a helper then it may be easier to just keep the drawers installed in the chassis during system installation.
4. Slide the drawer system into the vehicle by angling the driver side up. Line up the cutout with the sub and push the system towards the passenger side. Once you have the clearance lower the driver side of the drawer system. It helps to have the rear seat folded flat.

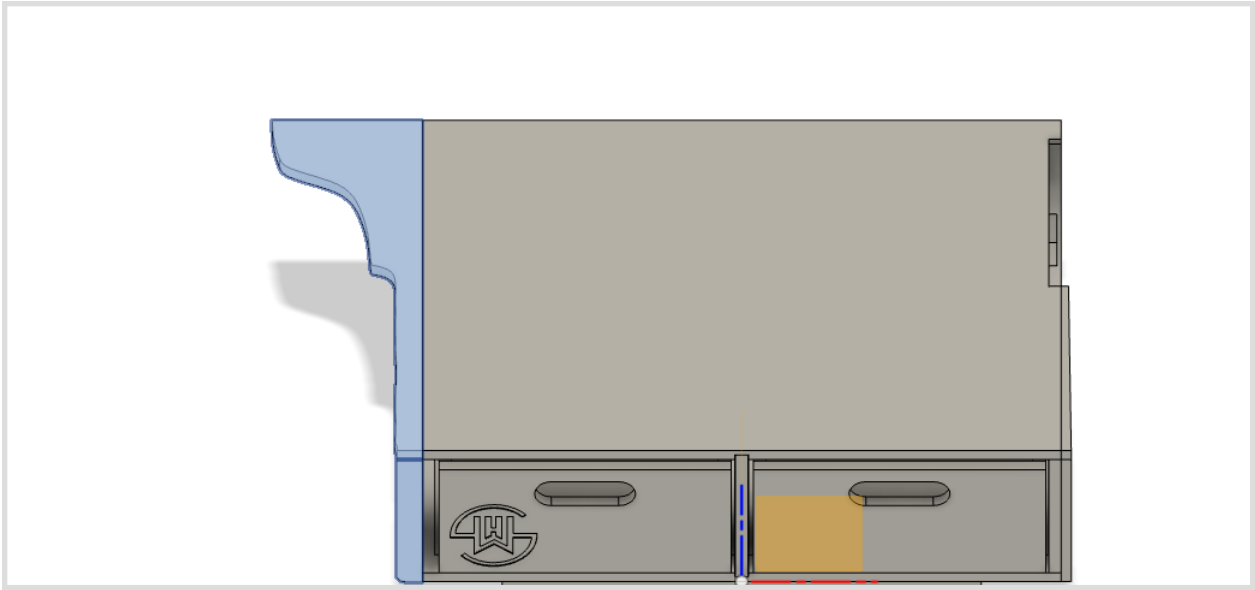

5. Shuffle the box so that you have the clearance to install the wing and the wing cap. The screws are driven from the inside of the chassis, find the predrilled holes. Start all the screws then drive them through once the pieces are lined up. Do not over tighten the screws! Install the wing cap before the wing. This step will require some patience, take your time.

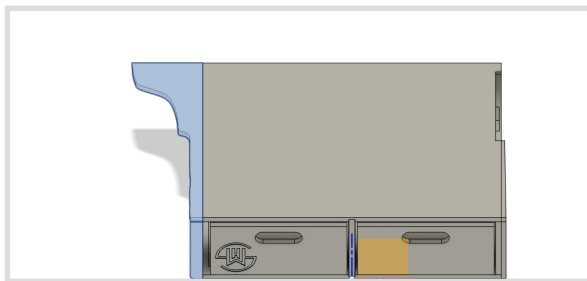

6. Line up the system and check to make sure you are happy with all the gaps with the trim. Install the mounting bolts in the base of the system. One in each corner will suffice. They only need to be snug, do not over tighten! Use hand tools for this step.

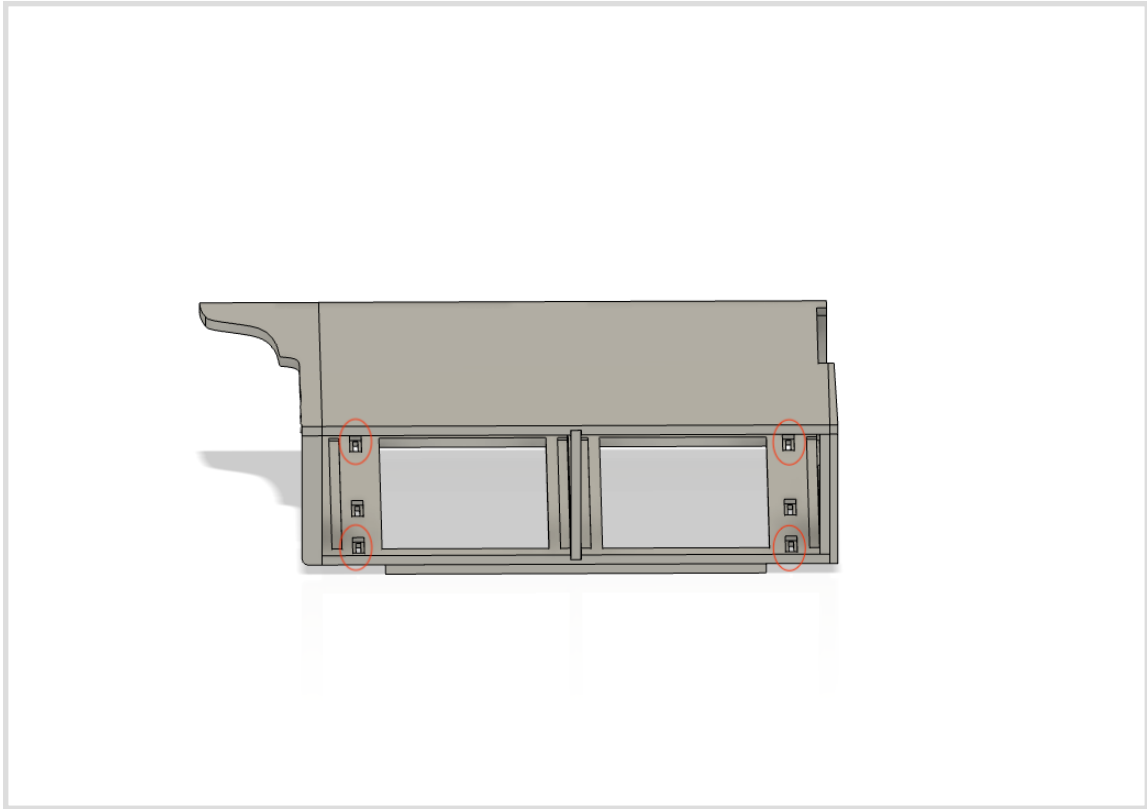

7. Reinstall the drawers into the chassis.
8. Enjoy your drawer system!